



Morgana CF2000
Lamination and Foiling

Morgana CF2000

Add **premium decorative effects** to your printed sheets with the ColorFlare **CF2000**.

The CF2000 is a compact, dual laminator and foil flaring device, designed to offer an in-house decorative effects solution for short-run, on demand digital applications, as well as lamination for traditional litho output too! With the ability to laminate and foil-flare straight out of the box, this high-quality production unit will soon start earning its keep, and you, a great reputation!

ColorFlare: Raising ordinary print work to 'extra-ordinary'. ColorFlare has been developed to meet specific print finishing requirements and built to exacting technical standards – with fully controllable pressure and heat processes, devised to deliver optimum results with today's digital print output. Both lamination and flaring-film rolls are available in a choice of widths and lengths to deliver great value for cost-effective production.

Market leading features

- Advanced dual roller process for digital lamination, film and foil technologies for digital applications
- Produce multiple jobs and flaring effects with just 1 machine
- No need to have traditional UV coating for special effects
- High hydraulic pressure for a smooth professional finish
- Semi auto feeding with overlap feature
- De-curl bar for flat sheet finish

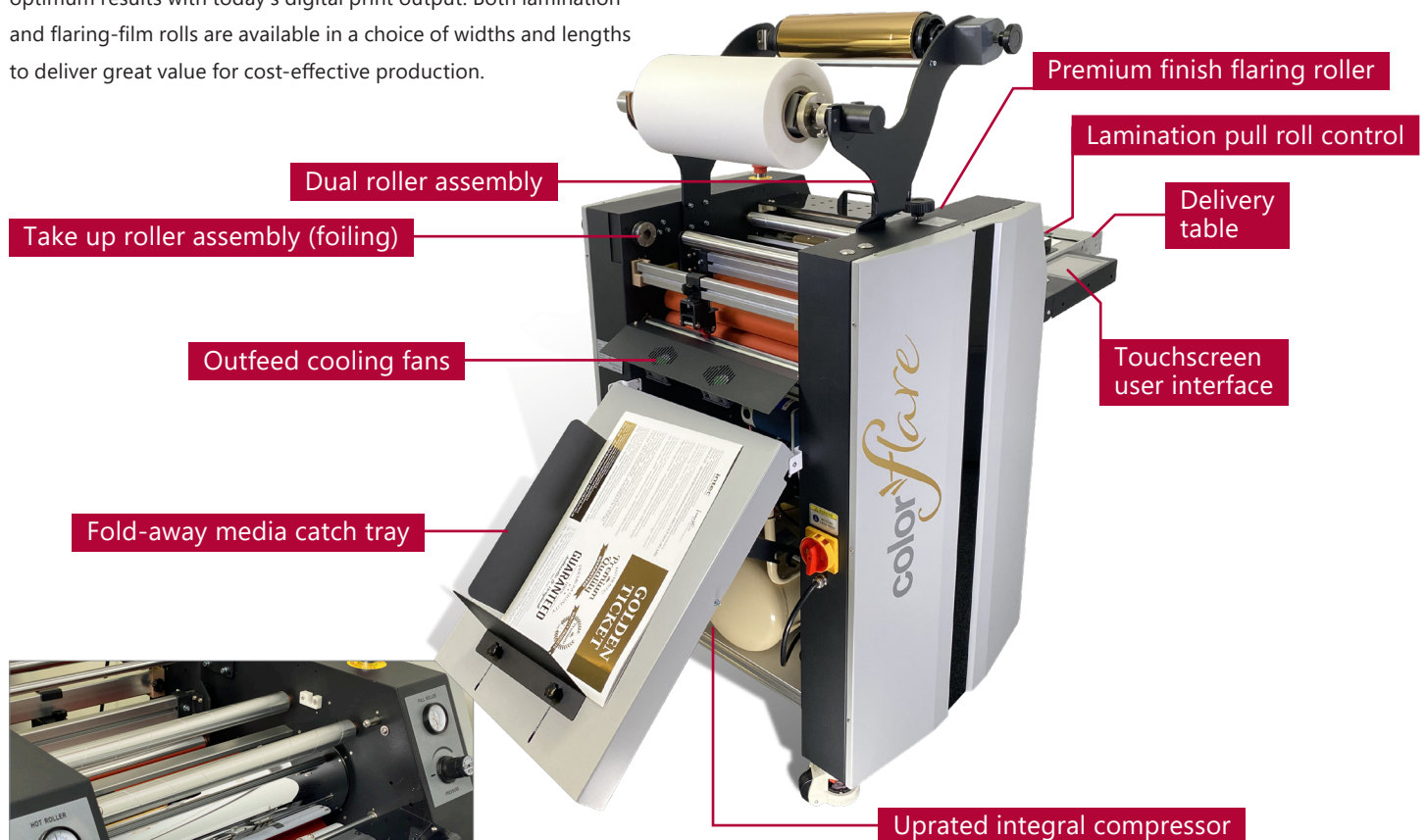

Premium oil heated, high gloss chromium roller, for mirror finish results



Laminates | Foils | Holographic fx

Faultless lamination

Class-leading lamination for the commercial printer. Using state-of-the-art technology, combined with integrated hydraulic pressure, the ColorFlare 2000 delivers superior bonding and faster production times – compared to standard systems. In addition, the fully adjustable heat and pressure combinations enable a wider range of laminates to be used with printed media, including the traditionally troublesome digital print output!

Stunning foil flaring

For today's printers who demand stunning results with that extra 'wow' factor – the ColorFlare delivers more than just class-leading lamination. Metallic, coloured, patterned or holographic style flaring foils can be added to digitally printed materials in either spot or flood treatments. This decorative effect is known as 'flaring', and traditionally, costly custom dies would be required to create these effects. However, ColorFlare can deliver instant and affordable results - and with upgraded hydraulic pressure, an even wider choice of media is now suitable for great results! Even further-advanced effects can be delivered by combining special corona-treated laminates with decorative effect flaring foils. Clever compound treatments deliver ultra premium results - all from one compact device!

Dual roller assembly

The dual arm roller assembly allows both laminates and metallic foils to be pre-loaded on the CF2000 - reducing change over times and enhancing productivity. Furthermore, this unique flaring roller assembly, enables dual - even multiple - metallic rolls, to be loaded for foiling of multiple metallics - all at the same time!

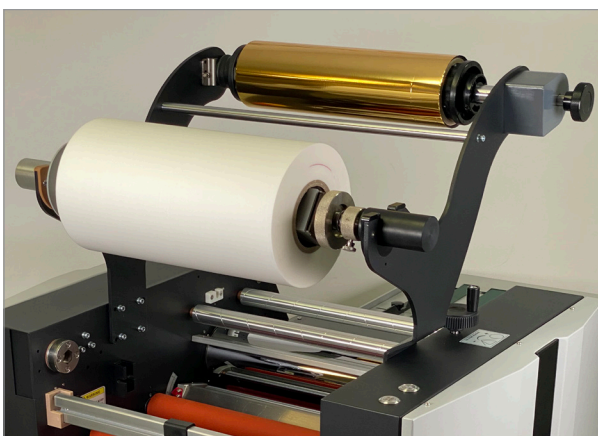

Dual roll assembly with pre-loaded laminate and foil rolls

Unique visual and tactile decoration

We have a range of specially formulated digital laminates, each featuring an advanced corona treatment, which enables subsequent overprinting through digital devices. This provides the opportunity to further enhance printed materials with additional decorative effects when using a combination of lamination and foil flaring. No ordinary laminating device can achieve anything like these unique and superb results!

Speedy and accurate production

Turnaround times and waste are further minimised with the ColorFlare unique 'burst separation' system. The laminating film is micro-perforated on the edge by the robust marking device and then separated by the burst roller. This easily separates the laminated sheets prior to the actual edge of the media, leaving clean and square datum edges from which to measure, cut, fold or guillotine. Other devices tend to need time-consuming and untrue manual separation.

One compact device

The flexibility to create and control stunning effects from just one compact device will lift ordinary print work to the level of extraordinary – and offers an even greater return on investment.

Touch screen control

The integrated touch screen provides an easy to understand, visual control system with feature rich options that provide an advanced level of control over the CF2000.

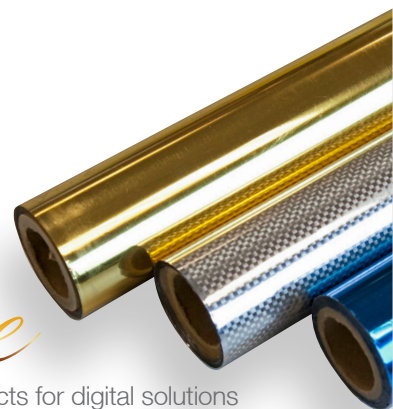

Technical Specification

Speed chart

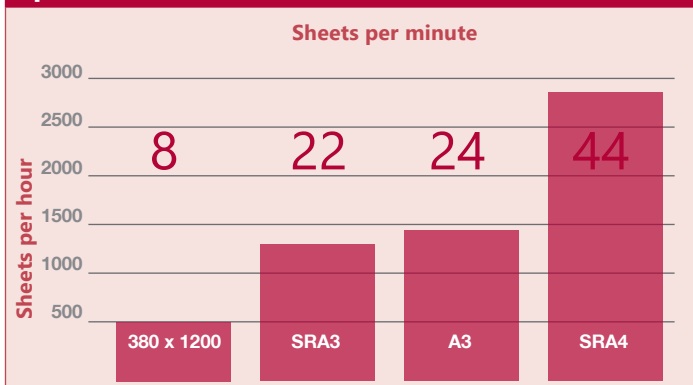

A growing range of consumables...*

Lamination films

Various finishes including: gloss, matt and silk touch, for litho and digital print. Digital laminates are corona-treated for subsequent over-printing.

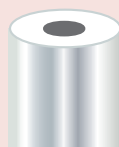

Foil flaring films

Available in a growing range of colours including: gold, silver, rose gold, copper, red, green, blue, black, white and clear gloss.

All can be applied direct to print.

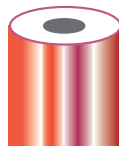

Holographic flaring films

Such as: sparkle, milky way, crystal, carbon fibre... Perfect for adding premium effects to print.

*See consumables support sheet.

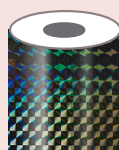

Morgana CF2000 Laminator and Foiler

Media sizes	Max: 390 x 1200mm Min: 200 x 300mm
Media thickness	150gsm to 400gsm
Lamination speed	1m/min ~ 15m/min
Laminating temperature	Max: 140°C
Heating mode	Oil heating
Roller pressure - hydraulic	1 metric tonne*
Laminate/Foil core size	3" (76mm)
Power supply	220~240v 50/60Hz, 3500W
Dimensions W D H	643 x 760 x 1136mm
Weight (unpacked) and crated	210kgs

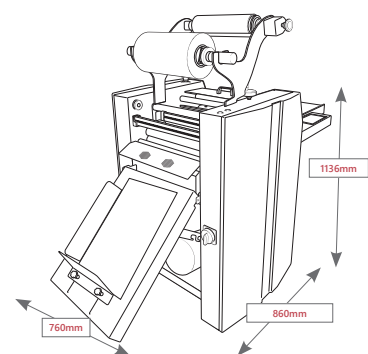

* actual reading is 970kgs

Мегатрейд – Офіційний дистриб'ютор Plockmatic Group в Україні
 03057, м. Київ, вул. Сім'ї Бродських, 31-33
 Тел. (044) 538-00-06, Email: printsales@megatrade.ua
www.megatrade.ua



MEGATRADE
 project distribution